



**GUJARAT ELECTRICITY REGULATORY COMMISSION  
GANDHINAGAR**

6<sup>th</sup> floor, GIFT ONE, Road 5-C, Zone 5, GIFT CITY, Gandhinagar – 382 355,  
Email [gerc@gercin.org](mailto:gerc@gercin.org)

Website: [www.gercin.org](http://www.gercin.org)

Date: 01/02/2024

**No. GERC/ITD/2024/Short-Tender/ AV system for Court proceedings**

**Last date: 15<sup>th</sup> February, 2024 on/before 06:00 PM**

**SUB: Sealed Tenders are invited for supply of material, installation and commissioning of Audio Video System for the Court Proceedings via Video Conferencing for GERC, Gandhinagar.**

Dear Sir/Madam,

Gujarat Electricity Regulatory Commission (GERC) invites sealed tender are invited from vendors for supply of material, installation and commissioning of Audio Video System for the Court Proceedings via Video Conferencing for GERC, Gandhinagar on the following terms & conditions:

1. The tender documents shall comprise following details:

- a.) Cover Letter
- b.) The Technical Specification should include the detailed specifications of main equipment/item and its accessories.
- c.) The Financial Bid should include the cost of main item/equipment, and its accessories.
- d.) Total bid price should be inclusive of all Taxes/GST and levies, transport, loading, unloading etc.
- e.) The total cost should be quoted in words as well as figures.

The vendor/bidder(s) should download the tender document from the GERC website ([www.gercin.org](http://www.gercin.org)). The vendor/bidder(s) are required to submit the downloaded tender document with the stamp and signed as acceptance of terms and conditions of the tender. Moreover, the financial bid are required to submit on vendor/bidder(s) letterhead with properly endorsed. Incomplete tenders, amendments and additions to tender after opening or late tenders are liable to be ignored and rejected.

2. Fax and Email quotation are not acceptable.
3. Bid/Quotations should be valid for 120 days from the tender due date. The Bid/Quotation should clearly indicate the period of delivery, warranty terms etc.
4. The bidder should have adequate facilities, trained manpower and staff for installation, commissioning and providing maintenance support service after the sales of the equipment. The bidder should provide support on a regular basis with technology/product updates under the warranty terms.
5. The Suppliers should submit copies of suitable documents in support of their reputation, credentials and past performance about the product/equipment, which they have supplied to other Government/Private Companies(s)/Organisation(s)/Institution(s).
6. The tender document must be accompanied by copy of PAN, Certificate of firm/company registration, TIN/GSTIN No.
7. The Vendor must be able to provide/supply the cited items within 30 days period from the date of the Purchase Order. In case if any delay on the part of vendor the same may be justified through email/letter. Failing the delivery/supply period by due date, EMD will be forfeited. Furthermore, on completion of the stipulated time period, Purchase Order will be cancelled and award will be given to another qualified bidder with the negotiated terms & conditions.
8. Any deviation in the material and the specifications from the accepted terms may liable to be rejected and the suppliers need to supply all the goods in the specified form to the satisfaction /specifications specified in the Purchase order and demonstrate at the their own cost.
9. The Payment will be made within 30 days after supply/delivery and successful installation of the items/equipments at GERC, Gandhinagar.
10. Each firm shall submit only one Tender, either by himself or as a partner in a joint venture. A firm which submits or participates in more than one Tender, will be disqualified.
11. The bidders are expected to provide clarifications in writing only on such points as specifically called upon to do so by GERC.

12. Preference will be given to local vendor for better on-going support and maintenance.
13. The Vendor should have relevant experience in successful completion of Audio/Video, Video Conferencing solutions in Commercial Buildings, Corporate Offices, Public Sector Undertakings, Government Projects etc.
14. The bidder is at liberty to visit the Gujarat Electricity Regulatory Commission (GERC) site (Court Room), before submitting the Tender, if the bidder desired.
15. Conditional Tender shall not be accepted.
16. Turnover in each of the immediately preceding three financial years should be more than Rs. 20 lakhs. (FY 2020-21, FY 2021-22, FY 2022-23).
17. Should have employed experienced personnel.
18. Eligibility criteria for Technical bid qualification is mentioned at **Form C**.
19. The Technical Specification for Audio Video System for the Court Proceedings via Video Conferencing for GERC is mentioned at **Annexure – I**.
20. No pricing information shall be included in the Technical Bid.
21. For better understanding of Audio Video System for the Court Proceedings via Video Conferencing for GERC, a schematic diagram is prepared and kept at **Annexure – II**.
22. The Financial Bid must be mentioned in the prescribed format as per the **Annexure – III** only.
23. The firm will give the undertaking that they are not blacklisted by any Government Organization as per **Annexure - IV**.
24. **Bid Evaluation** - The Technical Bids submitted by the bidders will be evaluated on a maximum of 100 marks. Minimum qualifying marks required to be qualified in technical bids is 70 on 100. 70% weightage will be given for technical bid and 30% weightage for financial bid.

25. The Financial Bid will be open on **22/02/2024** at **12:00 PM** at GERC Gandhinagar Premises.

a.) The suppliers or their authorized representative may also be present during the opening of the Financial Bid, if they desire so, at their own expenses.

b.) Only those Financial Bids will be opened whose Technically Bid is qualified and found suitable by the committee.

c.) The Tender Committee reserves its right to select or reject any or all of the items/equipment mentioned above without assigning any reasons.

26. A live demonstration with material is required before execution of Order. After successful testing and commissioning of the Audio Video System, 90% payment of the contract value will be paid along with taxes and duties within 30 days against receipted challans and submission of requisite documents. The balance 10% payment shall be kept as performance guarantee which will be released on expiry of three months from the date of receipted challans and submission of requisite documents.

27. GERC, Gandhinagar reserves the rights to accept/reject any offer in full or in part without assigning any reason thereof. Any offer containing incorrect and incomplete information shall be liable for rejection.

13. Any effort by a vendor to influence GERC's tender evaluation, tender comparison or contract/order award decisions may result in the rejection of the vendor's tender and forfeiture of the vendor's EMD.

#### 14. Reservation of Rights

To take care of unexpected circumstances, GERC reserves the rights for the following

1. Extend the closing date for submission of the Bid proposals;
2. Amend the Bidding requirements at any time prior to the closing date, with the amendment being notified to prospective Bidders and on the respective websites;
3. Terminate or abandon the Bidding procedure or the entire Project whether before or after the receipt of Bid proposals;

4. Make enquiries of any person, company or organization to ascertain information regarding the Bidder and its Proposal;
15. A demand draft of **Rs. 15,000/- (Fifteen Thousand Only)** towards refundable EMD from a Nationalized bank/Schedule bank in favor of “**GERC Gandhinagar**” payable at Gandhinagar placed in a separate envelope marked “**EMD**” should accompany bid documents. Without the EMD the bid will not be considered. However, EMD exempted to MSEs on submission of valid certificate.
16. The EMD of the successful bidder will be returned to them without any interest after completing the successful installation. The EMD of unsuccessful bidders will be returned to them without any interest within thirty (30) working days after completion of tending process.
17. All tender documents should have to be forwarded through speed post or registered post, courier, Hand Delivery to the following address so as to reach the following address on/before **15/02/2024 at 06:00 P.M.**

**Director (Adm & Accs)**

Gujarat Electricity Regulatory Commission,  
6<sup>th</sup> Floor, GIFT ONE, Road 5-C, Zone 5, GIFT CITY,  
Gandhinagar – 382355  
Gujarat, India.

**Sd/-**

**Director (Adm & Accs)**  
**Gujarat Electricity Regulatory Commission**

**Date: 01/02/2024**

**Place: Gandhinagar**

## FORM A

### PARTICULARS TO BE FILLED BY THE BIDDER

1. Name of the Vendor:
2. Complete Address of the Vendor:
3. Earnest Money Deposit enclosed:
  - a.) Name of the Bank \_\_\_\_\_
  - b.) Amount in (₹) \_\_\_\_\_
  - c.) Demand Draft No. \_\_\_\_\_
4. Communication details of the concerned contact person to whom all references shall be made regarding this tender enquiry. [NOTE: Any changes after submission of Tender documents kindly update GERC Gandhinagar]

Sr. No.	Particulars
1.	Name of the Tenderer
2.	Original documents attached indicated in the tender document <ol style="list-style-type: none"><li>i. 'Letter of Authorization' from Original Equipment Manufacturer (OEM)/Principal on the same and specific to this tender</li><li>ii. Relevant document related to the experience to supply the same item/equipment to the Companies/Institutions/organizations</li></ol>
3.	<ol style="list-style-type: none"><li>(a) Address</li><li>(b) Mobile No. /Telephone No.</li><li>(c) Fax No.</li><li>(d) E-Mail Address</li></ol>
4.	Registration Details <ol style="list-style-type: none"><li>(a) PAN No.</li><li>(b) TIN No.</li><li>(c) Service Tax/GSTIN No.</li></ol>

**FORM B**

**FINANCIAL DETAILS OF THE ORGANISATION**

<b>Financial Information</b>			
	FY 2020-21	FY 2021-22	FY 2022-23
Turnover (in INR crores)			
Profit Before Tax (in INR crores)			
Other Relevant Information			
Mandatory Supporting Documents:  a. Auditor Certified financial statements for the Last three financial years; 2020-21, 2021-22, 2022-23			

## FORM-C

### ELIGIBILITY CRITERIA FOR TECHNICAL BID

<b>Sr. No.</b>	<b>Eligibility Criteria</b>	<b>Bidders Response</b>	<b>Documents Required</b>
1	Experience of having successfully completed works during last Ten years ending previous day of last date of submission of bid.	Yes/No	Memorandum of Association
2	Vendor establishes a fully equipped local office in Ahmedabad, complete with a dedicated support team, to cater to emergency services.	Yes/No	Local GST No. document
3	Vendor should have experience in similar Audio-Visual (AV) projects of project value of atleast Rs. 20 lakhs.	Yes/No	(i) Copy of work order/purchase order and (ii) Work completion certificate
4	MAF (Manufacturer's Authorization Form) is required for all products.	Yes/No	MAF Form
5	All active products, including Gooseneck Microphones and DSP must be of the same make.	Yes/No	Data Sheet
6	The bidder must have a certified engineer from the Original Equipment Manufacturer (OEM) for the proposed solution.	Yes/No	OEM Certificate
7	All products should come with a minimum Two Year warranty.	Yes/No	OEM Certification



## Annexure-I

### Technical Specifications of the products

Sr. No.	Particulars	Technical Specifications
1	<b>Gooseneck microphone</b>	Audio frequency bandwidth :- 70 - 18000 Hz Equivalent noise level :- 30 dB-A Signal to Noise :- 64 dB-A Electrical impedance :- 600 Ohms Recommended load impedance :- 2000 Ohms TypeBalanced XLR Gender :- Male Contacts :- 3-pin Finishmatte :- black Voltage :- 9 to 52 V Current :- 3 mA Documents to be provided on OEM letterhead duly signed & stamped Technical compliance on OEM letterhead duly sign and stamp OEM confirmation to complying to GFR 144 xi restriction of procurement from a country which shares a land border with India
2	<b>Full HD PTZ VC Camera</b>	Lens: 12x maximum zoom, Focal length: 4.4 mm - 52.8 mm, F1.8 - F2.6 Minimal Illumination: 0.5 Lux @ (F1.8, AGC ON) Shutter: 1/30s – 1/10000s White Balance: Automatic, indoor, outdoor, one-button, manual, specified color Backlight Compensation: Supported Digital Noise Reduction: 2D & 3D Video S/N: ≥55dB Horizontal Angle of View: 71° – 8.2° Vertical Angle of View: 42.7° – 4.5° Horizontal Rotation Range: ±170° Vertical Rotation Range: -30° – +90° Pan Speed Range: 2.7° – 35.7°/s Tilt Speed Range: 2.7° – 31.5°/s H & V Flip: Supported Image Freezing: Supported Number of Presets: 255 Flexible Installation: Standard mount, upside-down mount Operating Systems: Windows 7 and later Color System: YUY2 / MJPEG USB Video Communication: UVC 1.1 Audio on USB: Supported UVC PTZ: Supported Operating Temperature: 14°F–104°F (-10°C – 40°C)

Sr. No.	Particulars	Technical Specifications
		<p>Storage Temperature: -40°F – 140°F (-40°C – 60°C)</p> <p>MTBF: &gt;30000h</p> <p>Audio Interface: 3.5 mm connector, Line In</p> <p>USB Interface: 1 way, USB 3.0, Type C Socket</p> <p>1 x RS232: 8pin Min DIN; Max. Distance: 30 m;</p> <p>Protocol: VISCA/Pelco-D/Pelco-P</p> <p>1 x RS485: 2pin phoenix port; Max. Distance: 1200 m;</p> <p>Protocol: VISCA/Pelco-D/Pelco-P</p> <p>Control the camera's functions via IR remote, RS-232, or UVC protocol</p> <p>Super-high SNR with advanced 2D and 3D noise reduction.</p> <p>Compatible with popular applications such as Zoom, WebEx, Google-Meet</p> <p>USB 3.0/2.0 compatibility with UVC and UAC protocols support</p> <p><b>Video System:</b></p> <ul style="list-style-type: none"> <li>• 2160p30</li> <li>• 1080p30</li> <li>• 1080p25</li> <li>• 720p30</li> <li>• 720p25</li> </ul> <p>Ceiling mount stand for the mounting will be same make of Camera</p> <p>Documents to be provided on OEM letterhead duly signed &amp; stamped</p> <p>Technical compliance on OEM letterhead duly sign and stamp</p> <p>OEM confirmation to complying to GFR 144 xi restriction of procurement from a country which shares a land border with India</p>
3	<b>Digital Signal Processor with USB Extender</b>	<p>12 Analog Inputs (with 48v Phantom Power per Channel)</p> <p>8 Analog Outputs</p> <p>9 Configurable Signal Processing</p> <p>12 Channels of AEC Processing with Auto Gain Control and Noise Cancellation</p> <p>48 Channel, Low Latency, Fault Tolerant Digital Audio Bus</p> <p>Bi-Directional Locate Functionality</p> <p>12 Control Inputs and 6 Logic Outputs for GPIO Integration</p> <p>HiQnet Device</p> <p>Connectors : 2 x RJ45 Ethernet connectors</p> <p>AEC Processing : 12 independent algorithms</p> <p>Operating Temp. Range:15 (59) to 35 (95) degrees C (degrees F)</p> <p>USB Audio Interface, Should be capable to transfer 8 Inputs and 8 output audio channel to and from DSP, Shall support both Windows PC/Laptop and Apple Mac Desktop/Laptops</p> <p>1 Ethernet port for Monitoring and configuration</p> <p>Capable to handle +5V unloaded logic output voltage</p> <p>Should have speech sense engine</p> <p>Capable to control 3rd party devices with TCP IP and RS 232</p> <p>Should have monitoring LED for COM, STAT, ERR and PWR</p>

Sr. No.	Particulars	Technical Specifications
		12 x 8 Networked Digital Signal Processor With AEC Documents to be provided on OEM letterhead duly signed & stamped Technical compliance on OEM letterhead duly sign and stamp OEM confirmation to complying to GFR 144 xi restriction of procurement from a country which shares a land border with India
4	<b>Splitter</b>	HDMI (3D, Deep Color, 4K); HDCP 2.2 Compatible Supports HDR10+ Supports max resolutions of up to 4096 x 2160 / 3840 x 2160 @ 60 Hz (4:4:4) Data rate up to 18 Gbps Operating Temperature 0° to 40° C Storage Temperature -20° to 60° C Humidity 0 - 80% RH, Non-Condensing Video Input Interfaces :- 1 x HDMI Type A Female (Black) Video output Interfaces :- 4 x HDMI Type A Female (Black) Documents to be provided on OEM letterhead duly signed & stamped Technical compliance on OEM letterhead duly sign and stamp OEM confirmation to complying to GFR 144 xi restriction of procurement from a country which shares a land border with India
5	<b>HDMI HDBase Extender</b>	HDBaseT-Lite Extender extends an HDMI signal up to 70m from the HDBaseT source using one Cat 5e / 6 / 6a cable. It supports HDMI features that include 3D, Deep Color and 4K image resolutions, plus Dolby Digital 5.1, DTS HD audio and it is HDCP compatible Max. Data Rate 10.2Gbps (3.4Gbps per lane) Max. Pixel Clock 340 MHz Compliance HDMI (3D, Deep Color, 4K); HDCP 2.2 Compatible Consumer Electronics Control (CEC) Max. Resolutions / Distance Up to 4K @ 35m (Cat 5e / 6) / 40m (Cat 6a / ATEN 2L-2910 Cat 6); 1080p @ 60m (Cat 5e / 6) / 70m (Cat 6a / Cat 6) *4K supported: 4096 x 2160 / 3840 x 2160 @ 60Hz (4:2:0); 4096 x 2160 / 3840 x 2160 @ 30Hz (4:4:4) Operating Temperature 0 - 50 °C Storage Temperature -20 - 60 °C Humidity 0 - 80% RH, Non-Condensing
6	<b>HDMI Cable (1.5, 5 , 10 , 15, 20 Meter)</b>	Ultra-Flexible High Speed 2.0 HDMI (Male to Male) Cable, Gold plated contacts, Supports signals up to 4K@60Hz (4:4:4), HDCP 2.2, EDID, HDR Compliance.
7	<b>Display Mount</b>	Ground level Display stand Ideal for Up to 40 inch and above with universal VESA Up to 600 x 400 , Metal base for stable Display with Lockable arrangement, tilt angle for full Viewing Flexibility along with Floor mounting Necessary Accessories

<b>Sr. No.</b>	<b>Particulars</b>	<b>Technical Specifications</b>
8	<b>Speaker Cable</b>	16 AWG Speaker Cable in existing conduit. Two X 16 AWG conductors, High performance cable for audio signals, Non- Plenum.
9	<b>Control &amp; Mic Cable</b>	Dual 20 AWG shielded twisted pairs with individual drain wires, High performance cable for serial control/audio signals, Non-Plenum.
10	<b>Audio Convertor</b>	XLR Converter
11	<b>USB Cable (2, 5, 10, 15 Meter)</b>	Optical USB-C (M) to USB-C (M) Cable with required USB Connector as per site requirement to convert in to USB A & USB B Type cable.
12	<b>Network Cable</b>	LAN Cable - 23 AWG Solid Bare Copper (4 pair)
13	<b>PVC Pipe</b>	25 MM PVC Pipe + 25 MM Flexible Pipe (ISO Approved)
14	<b>Power Cable</b>	3 C x 2 Sqmm Power Cable (ISO Approved)

# Annexure -II

## **SCHEMATIC DIAGRAM for Audio Video System of GERC Court Room**

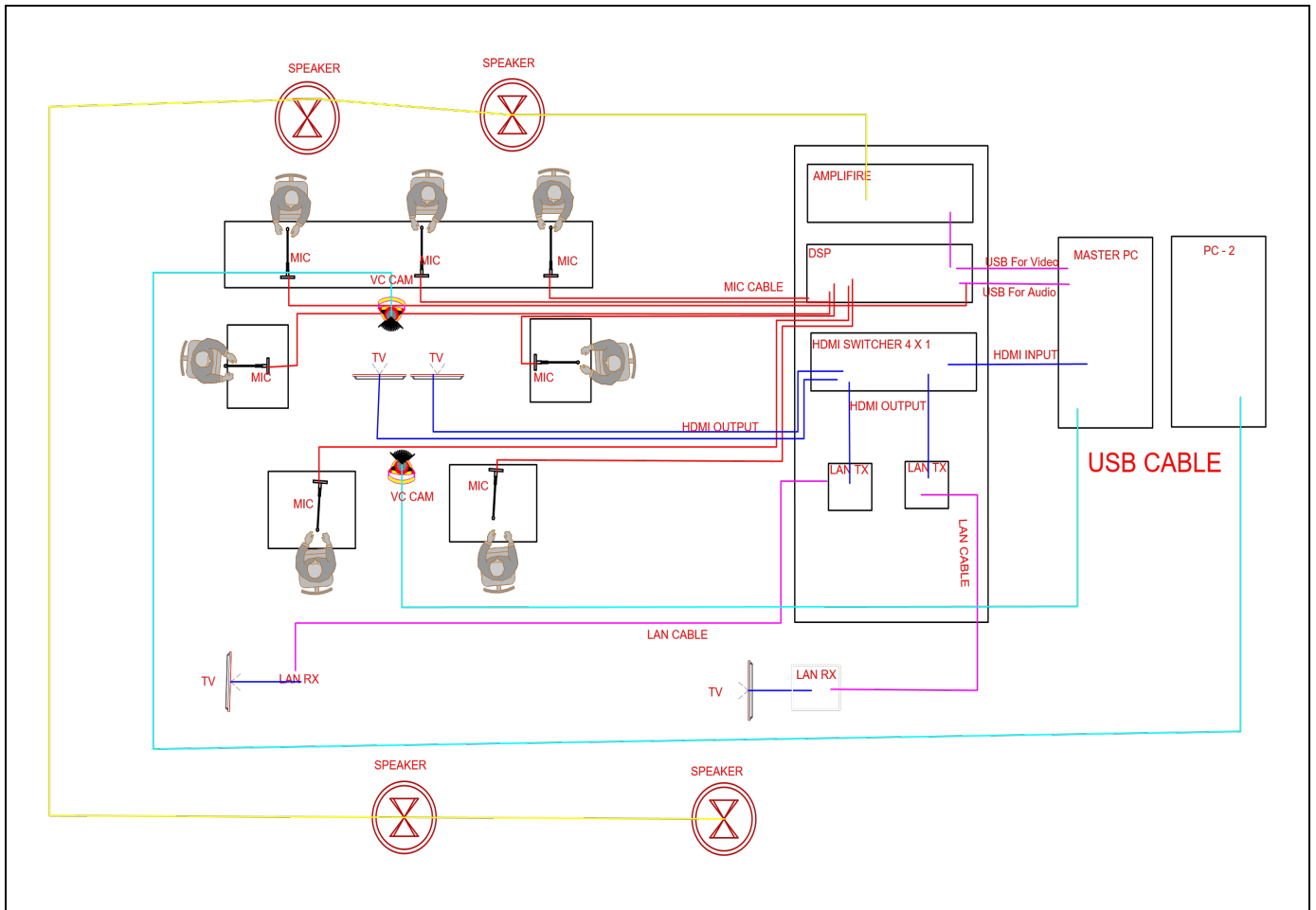

## ANNEXURE - III

### FINANCIAL BID

Sr. No.	Particulars	Qty	Price in Rs.	GST (%)	Total Price inclusive GST
	A	B	C	D	E= C+D
1	Gooseneck microphone	7			
2	Full HD PTZ VC Camera	2			
3	Digital Signal Processor with USB Extender	1			
4	Splitter	1			
5	Display Mount	2			
6	HDMI HDBase Extender	2			
7	HDMI Cable of 1.5 mtr length	4			
	HDMI Cable of 15 mtr length	2			
8	Speaker Cable of 200 mtr length	1			
9	Control & Mic Cable of 100 mtr length	1			
10	XLR Audio Convertor	7			
11	USB Cable of 20 mtr length	2			
12	Network Cable of 70 mtr length	1			
13	PVC Pipe of 125 mtr length	1			
	Flexible PVC Pipe of 25 mtr length	1			
14	Power Cable – 50 mtr	1			
15	Supply, Installation, Testing and Commissioning	-			
	<b>Grand Total (Net Price)</b>				

**Delivery Mode : Delivery at GERC Gandhinagar**

**Notes:**

- Net price should be inclusive of all taxes/GST and levies, transport, loading, unloading etc.
- Delivery Period: .....days/weeks. (max. 30 days)
- Bid/Quotation Validity Date: - Minimum 120 Days from the date of Submission of quotation/tender.
- Payment Term: The Payment will be made within 30 days after supply/delivery and successful installation of the items/equipments at GERC, Gandhinagar.

Name of the bidder:- \_\_\_\_\_

Firm's Name:- \_\_\_\_\_

Date: - \_\_\_\_\_

Sign of bidder: - \_\_\_\_\_

## ANNEXURE - IV

### DECLARATION

1. I, \_\_\_\_\_ Son/Daughter of Shri \_\_\_\_\_ Proprietor/Partner/Director/Authorised Signatory of \_\_\_\_\_ is /am competent to sign this declaration and execute this tender document.
  
2. I have carefully read and understood all the terms and conditions of the tender and hereby convey my acceptance of the same.
  
3. The information/documents furnished in the above tender document alongwith technical specification are true and authentic to the best of my knowledge and belief. I/we, am/are well aware of the fact that furnishing of any false information/fabricated document would lead to rejection of my tender at any stage besides/fabricated towards prosecution under appropriate law.
  
4. I declare that my company/firm/agency is authorised suppliers/dealers for sale/supply of items as mentioned in Annexures.

Signature of Authorised Person

Date:

Full Name:

Place:

Company's Seal: